

Model HB74 HEAVY DUTY digital multimeter

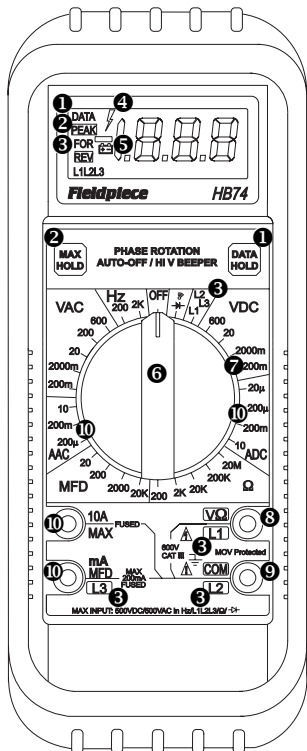

OPERATOR'S MANUAL



Display and Controls

- DATA HOLD** freezes display with the touch of a button, indicator in LCD turns on. A second touch resets.
- MAX HOLD** remembers the largest number displayed, indicator in LCD turns on. Second touch resets.
- Phase rotation** feature identifies phase relationship of three phase power. "L1L2L3" in LCD identifies which connections have been made. "FOR" indicates L1, L2, and L3 are connected in order. "REV" indicates you must switch any two leads.
- Indicator lights and beeper sounds intermittently when connected to voltages greater than 30V.
- Low battery indicator.
- Single rotary switch for function and range selection. Abbreviation used:
 Hz Frequency
 L1L2L3 Phase rotation
 MFD microfarads (capacitance)
 Ω Ohms
)))→ Continuity beeper or diode test
- Most accessories use 200mVDC range. For readings over 200, use the 2000mVDC range. Use 200mVAC or 2000mVAC range for the AC current clamp accessory.
- For volts, ohms, or measurements using any accessory, use this jack and COM.
- Always plug one test lead in this jack.
- For testing current going **through** the meter (i.e. NOT using an amp clamp accessory) use one of these jacks (& COM) and one of these switch positions.

Safety Precautions

Never ground yourself when taking electrical measurements. Do not touch exposed metal pipes, outlets, etc., which might be at ground potential. Keep your body isolated from ground with rubber shoes, rubber mats, or any approved insulating material.

Warning

Under no circumstances exceed these ratings: 600VAC/600VDC on voltage ranges (500VDC/350VAC on 200mV range); 500V (AC or DC) on ohms, diode/continuity, frequency, and phase rotation range; 200mA/500V on mA jack; 10A/600V on A jack.

Fully discharge capacitors before testing!
Do not use the ACH 300A clamp head on uninsulated conductors above 600VAC.

Disconnect the meter from the circuit before turning any inductor off, including motors, transformers, and solenoids.

To prevent electrical shock hazard, turn off the multimeter and disconnect test leads before removing the back cover.

Do not use during electrical storms.

Symbols Used:

CE Certified Meets the requirements of IEC 1010 CATIII

Risk of electric shock.

Caution, refer to manual.



Tested and listed by underwriter labs

Ground.

Double insulation.

Multimeter Setup

Selecting Ranges

For DC voltage, set the meter to the VDC parameter instead of VAC as shown (right).

For all ranges and functions choose a range just above the value you expect. If display reads "OL" (overload), select a higher range. If display shows less than three numbers, select a lower range for better resolution.

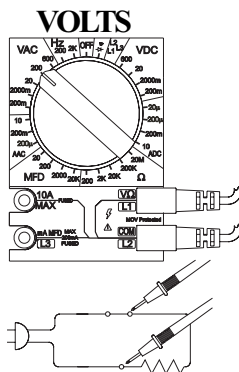

RESISTANCE

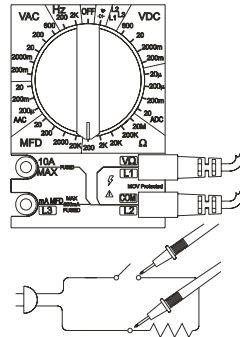

FREQUENCY (Hz)

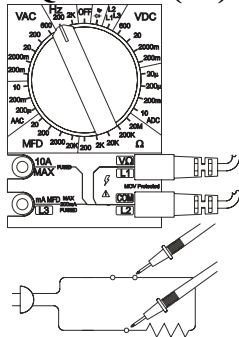

CAPACITANCE (MFD)

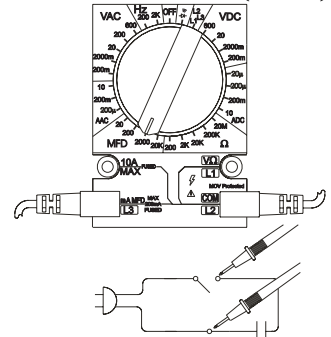

PHASE ROTATION

The terminals on most three phase motors are marked L1, L2, and L3. The wires supplying power are not marked making it impossible to determine which direction the motor will turn. The HB74 solves this problem.

Connect meter jacks marked L1, L2, and L3 to the power wires in any order. Make sure all three leads are connected (L1, L2, and L3 appear "on LCD"). "FOR" indicates "forward" and means that you can connect L1 on the meter to L1 on the motor, L2 on the meter to L2 on the motor, and L3 on the meter to L3 on the motor and the motor will turn in the direction designed. If "REV" is displayed, swap any two leads to correct it and display "FOR".

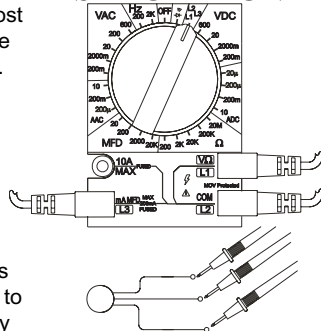

AMPS W/ CLAMP

Test amps up to 300AAC when using the Fieldpiece accessory model ACH. The model ACH current clamp tests amps at a conversion rate of 1mVAC per 1AAC (1000 to 1). Measure AC amps with a resolution of 0.1A. No need to mentally move decimal points.

To connect the ACH current clamp head to the meter, remove the tips from the ADL2 leads or use the AHDL1 adapter handle.

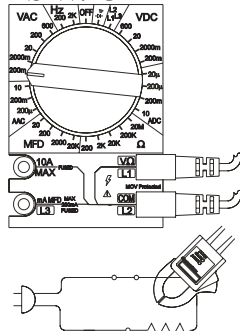

AMPS < 200mA *

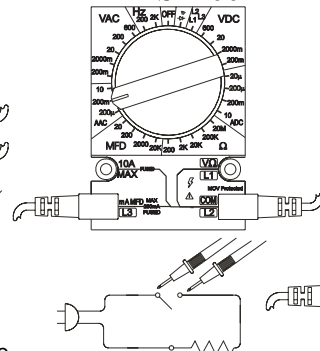

AMPS to 10A

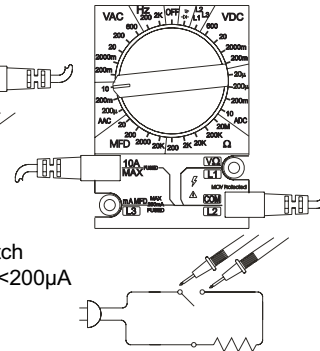

* Use 200µA switch position for amps < 200µA

Functional Specifications

Accuracy specifications good for 75°F±5°F, relative humidity less than 70%. Accuracy specified as ±% of reading ± number of least significant digits. For example if the actual parameter is 100 and the accuracy is specified as 1%±3, the measurement could be as high as 101.3 or as low as 98.7 on the 200 scale.

AC voltage (50Hz-500Hz)

Ranges: 200mV, 2000mV, 20V, 200V, 600V

Resolution: 0.1mV on 200mV range

Accuracy: 1.2%±2 @ 50Hz to 500Hz; 2%±5 @ 500Hz to 1KHz; 2%±5 @ 50Hz to 500Hz on 600VAC range

Input impedance: 10M Ω

Conversion type: Average measuring, rms indicating (sine wave)

DC voltage

Ranges: 200mV, 2000mV, 20V, 600V

Resolution: 0.1mV on 200mV range

Accuracy: 0.5%±1

Input impedance: 10M Ω

Resistance

Ranges: 200 Ω , 2K Ω , 20K Ω , 200K Ω , 20M Ω

Resolution: 0.1 Ω on 200 Ω range

Accuracy: 1%±1 on 200 Ω to 200K Ω ranges, 3%±4 on 20M Ω range

Open circuit voltage: <0.3V, <3V on 200 Ω range

Test current: <2mA

Capacitance

Range: 20MFD, 200MFD, 2000MFD, 20KMFD (microfarads).

Accuracy: 4%±10

Tested at: 3V/21Hz

Diode test

Range: 2K Ω

Accuracy: 1%±1

Resolution: 1mV

Test current: 1.0±0.6mA

Open circuit voltage: 3.2V max

Measures forward voltage drops across diodes and transistor junctions. Forward: red test probe to anode. Shunting resistors under 1Kohm must be removed from the circuit.

DIODE TYPE	FWD OK	REV OK	SHORT	OPEN
Silicone	0.6V	"OL"	0.0V	"OL"
Germanium	0.3V	"OL"	0.0V	"OL"

Fuse Test

If no current and capacitance measurements are possible, the fuse may be blown.

You can check fuses without opening the case. For 20A fuse: short VOHms<-->20A jacks, put dial on continuity/diode check. Beeper sounds and display shows near zero if 20A fuse is good. It shows "OL" if fuse is bad.

For mA fuse: short COM<-->mA MFD (test lead from COM to mA MFD jack), put dial on any MFD range. If display stays near zero, fuse is bad. If display starts counting up in a second or two, fuse is good.

Test Lead Safety

Inspect test leads for damage. Replace if suspect. Ensure that the test leads are fully inserted into the proper terminals. Check continuity by selecting continuity/diode range (first position to right of OFF). Short VOHms<-->COM jacks. Listen for continuous beep. If no continuous beep is present, the leads need to be replaced.

AC current

Ranges: 200 μ A, 200mA, 10A

Resolution: 0.1 μ A

Frequency response: 50Hz to 500Hz

Accuracy: 1.5%±3 on 200 μ A to 200mA ranges; 3.5%±3 on 20A range.

Voltage burden: 250mV on 200 μ A range; 400mV on 200mA range; 600mV on 10A range.

DC current

Ranges: 20 μ A, 200 μ A, 200mA, 10A

Resolution: 0.01 μ A

Accuracy: 1.0%±1 on 20 μ A to 200mA ranges; 2.5%±1 on 10A range

Voltage burden: 250mV on 20 μ A, 200 μ A ranges; 400mV on 200mA range and 600mV on 10A range.

Frequency

Ranges: 200Hz, 2kHz (10Hz to 2kHz)

Resolution: 0.1Hz

Accuracy: 0.5%±3 on all ranges

Sensitivity: 2V RMS min.

Duty cycle limits: at >30% and <70%

Minimum pulse width: >150 μ sec

Overload protection: 500VDC or AC rms

Phase rotation indicator

Frequency range: 45Hz to 450Hz

Voltage range: 80VAC to 500VAC

Connection and display: Meter displays

"L1L2L3" when all three leads are connected;

"FOR" when they are connected in order.

"REV" means you need to swap any two leads.

Agency compliance

UL listed. CE certified to IEC1010 cat III 600V.



This unit complies with requirements of the following European Community Directives: 89/336/EEC (Electromagnetic Compatibility) and 73/23/EEC (Low Voltage) as amended by 93/68/EEC (CE Marking). However, electrical noise or intense electromagnetic fields in the vicinity of the equipment may disturb the measurement circuit. Measuring instruments also respond to unwanted signals that may be present within the measurement circuit. Take appropriate precautions to avoid misleading results when making measurements in the presence of electromagnetic interference.

The Fieldpiece HB series was designed in accordance with IEC Publication 1010-1, Class II, 'Safety Requirements for Electronic Measuring Apparatus' for use by trained professional technicians. The instrument complies with class II and pollution deg. 2 indoor use, overvoltage CAT III of the IEC 1010-1 (EN61010-1) standard. If the equipment is used in a manner not specified, the protection provided by the equipment may be impaired.

User Maintenance

Repairs or services not covered in this manual should only be performed by qualified personnel. Regular operator maintenance consists of periodic cleaning (case and window), battery replacement, fuse replacement and recalibration.



When servicing, use only specified replacement parts or equivalent.

General Specifications

Heavy duty: Case designed of hi-impact, fire retardant yellow Valox, fully "O" ring sealed

Display: 3 1/2 digit (LCD). Maximum reading of 1999

High Voltage beeper: ⚡ "lightning bolt" icon in LCD blinks and beeps intermittently in VAC and VDC ranges when connected to 30V or greater

Data HOLD: "locks" reading range

MAX hold: "MAX" holds the largest reading

Polarity: Auto., pos. (+) implied, neg. (-) indicator

Overrange: (OL) or (-OL) is displayed

Continuity beeper: (<150W) indicated by a continuous "beep" within 100 msec.

Low battery indicator: The "🔋" is displayed

Overload protection:

Volts: 600VAC/600VDC rms 500VDC/350VDC, (15 seconds in 200mV ranges). MOVs installed for transient protection up to 6KV/10msec.

Ohms/diode/continuity/Hz: 500VAC/DC

Phase rotation: 500VAC

Amps, capacitance: fast blow 0.5A/500Vmin (6.35X32mm) fuse (model RFM74) on mA jack, high energy 12A/600V(1.5X.375") fuse (model RFL712) on 10A jack.

Operating environment: 0°C-50°C at < 70% R/H

Storage temperature: -20°C-60°C, 0-80% R/H with battery removed from meter.

Temperature coefficient: 0.1 x (specified accuracy)/°C (< 18°C or > 28°C).

Measurement rate: 2.5 times/sec., nominal.

Auto-power off: Approx. 50 minutes.

Calibration cycle: 1 year.

Battery life: 300 hours typical with carbon-zinc.

Dimensions: 176mm (H) x 73mm (W) x 39mm (D). Wt. 340g.

Battery type: 9V NEDA 1604 type, IEC 6F22.

Two Year Limited Warranty

This meter is warranted to the original purchaser against defects in material or workmanship for a period of two (2) years from the date of purchase. During the warranty period, Fieldpiece Instruments will, at its option, replace or repair the defective unit, subject to verification of the defect or malfunction.

This warranty does not apply to defects resulting from abuse, neglect, accident, unauthorized repair, alteration, or unreasonable use of the instrument.

Any implied warranties arising out of the sale of a Fieldpiece Instrument's product, including but not limited to implied warranties of merchantability and fitness for a particular purpose, are limited to the above. The manufacturer shall not be liable for loss of use of the instrument or other incidental or consequential damages, expenses, or economic loss, or for any claim or claims for such damage, expenses, or economic loss.

State laws vary, so the above limitations or exclusions may not apply to you. This warranty gives you specific legal rights, and you may also have other rights which vary from state to state.

Obtaining Service

Send the meter freight prepaid to Fieldpiece Instruments. For warranty service also send proof of date and location of purchase. For out-of-warranty service send \$60, check or money order. Do not send cash. The meter will be repaired or replaced, at the option of Fieldpiece Instruments.



231 E. Imperial Hwy. Suite 250 Fullerton, CA 92835
(714)992-1239 Fax: (714)992-6541

opmHB74v25